SSI 3020

Digital Panel Meter



for Absolute Encoders with Synchron-Serial-Interface

Instruction Manual



ERMA

Electronic GmbH

Warranty

For delivered products our "Allgemeine Lieferungs- und Zahlungsbedingungen" are effective. In no event we or our suppliers shall be liable for any other damages whatsoever (including, without limitation, damages for loss of business profits, business interruption or other pecuniary loss) arising out of or inability to use this product.

All our products are warranted against defective material and workmanship for a period of two (2) years from date of delivery. If it is necessary to return the product, the sender is responsible for shipping charges, freight, insurance and proper packaging to prevent breakage in transit. The warranty does not apply to defects resulting from action of the buyer, such as mishandling, improper interfacing, operation outside of design limits, improper repair or unauthorized modification.

Trademarks

All trademarks that are named or portrayed in the text are registered trademarks of its owner. The trademarks are recognized by ERMA-Electronic.

CONTENTS

1. Description	5
2. Safety instructions	5
2.1. Symbol explanation	5
3. Mounting	6
3.1. Place of operation	6
3.2. Mounting of digital panel meter	6
3.2.1. Housing for switch board	6
4. Electrical connections	7
4.1. General instructions	7
4.2. Hints against noisy environment.	7
4.3. Connection and pin assignment	7
4.4. Connection of absolute encoder.	8
4.5. Connection of power supply voltage.	8
5. Startup Procedure	8
6. Pushbuttons- and LED-functions	9
6.1. Function of buttons and LEDs	9
7. Modes	10
7.1. Operation level.	10
7.2. Access-code level	10
7.3. Programming level.	11
8. Procedure of programming	12
8.1. Changing or controlling parameters	12
8.2. Overview of the programming levels	13
8.3. Programming level for configuration P-00.	14
8.4. Scaling the display range	15
8.5. Programming quick reference	15
9. Software functions	16
9.1. Master/Slave-Mode	16
9.2. Zero point adjustment	16

9.2.1. Zero point adjustment by pressing button	16
9.2.2. Zero point adjustment by offset value	18
9.3. Directions of rotations	18
9.4. Main reset	18
10. Error codes	19
10.1. Encoder not connected "Err01"	19
10.2. Waiting for data input "Err02"	19
10.3. External clock frequency too high "Err03"	19
11. Technical Specifications	20
11.1. Electrical datas.	20
11.2. Mechanical datas	20
11.3. Environmental conditions	21
12. Ordering Information	21
13. Notes	22

Stand : 28.07.2004
SSI3020A.VP
Technical subjects to change

1. Description

The digital panel meter Model SSI 3020 is an instrument for displaying and controlling absolute encoders with **Synchronous-Serial-Interface (SSI)**

Standard functions

- Zero point adjustment
- Offset value
- Scaling factor
- Master/slave

2. Safety instructions

This instrument is produced in accordance with Class II of IEC 348 and VDE 0411. When delivered the instrument has been tested to meet all functions described. Before installing the instrument please read the mounting and servicing instructions.

We have no liability or responsibility to customer or any other person or entity with respect to any liability, loss or damage caused or alleged to be caused directly or indirectly by equipment or software sold or furnished by us. Read the installation instruction carefully. No liability will be assumed for any damage caused by improper installation.

Inspect the instrument module carton for obvious damage. Be shure there are no shipping and handing damages on the module before processing. Do not apply power to the instrument if it has been damaged.

ERMA's warranty does not apply to defects resulting from action of the buyer, such as mishandling, improper interfacing, operation outside of design limits, improper repair or unauthorized modifications.

2.1. Symbol explanation



Caution

Attention

Instruction

Tip

Caution: Will be used at **dangerous for life and health !**

Attention: Will cause **damage**

Instruction: If not noticed, **trouble** may occur

Tip: Useful hints for **better operation**

3. Mounting

3.1. Place of operation

Attention must be paid to the protection against humidity, dust and high temperatures at the place of operation.

3.2. Mounting of digital panel meter

3.2.1. Housing for switch board

- Insert the case into the panel cutout (according to DIN 43700: $92^{+0,8} \times 45^{+0,6}$ mm)
- Tighten the screws alternately, using enough pressure to get good retention and sealing at the panel.

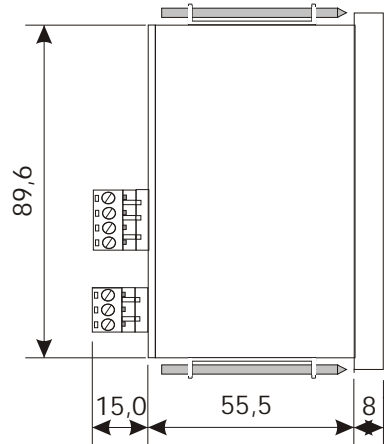
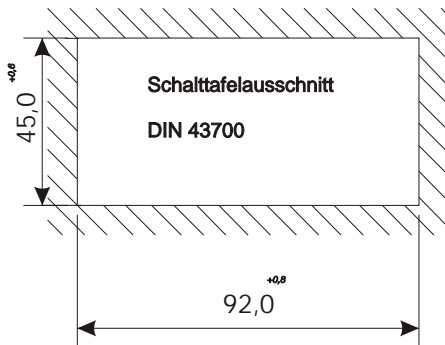
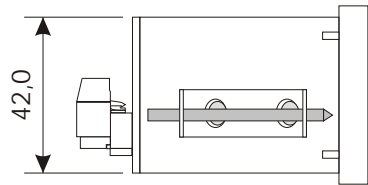
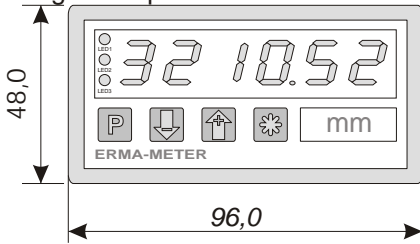

4. Electrical connections

4.1. General instructions



- It is forbidden to plug or unplug connectors with voltage applied
- Attach input and output wires to the connectors only without voltages applied
- Cords must be provided with sleeves
- Attention must be paid that the power supply voltage applied will agree with voltage noticed at the name plate.
- The instrument has no power-on switch, so it will be in operation as soon as the power is connected.

4.2. Hints against noisy environment

All inputs and outputs are protected against noisy environment and high voltage spikes. Nevertheless the location should be selected to ensure that no capacitive or inductive interference can have an effect on the instrument or the connection lines.

It is advisable:



- To use shielded cables.
- The wiring of shields and ground (0V) should be star-shaped.
- The distance to interference sources should be as long as possible. If necessary, protective screen or metal enclosures must be provided.
- Coils of relays must be supplied with filters.
- Parallel wiring of input signals and AC power lines should be avoided.

4.3. Connection and pin assignment

All inputs and outputs are connectors, designed as plug-in screw terminals.

Pin assignment:

Pin	Discription
1	SSI clock input +
2	SSI clock input -
3	SSI data input +
4	SSI data input -
9	GND
10	Power supply -
11	Power supply +



4.4. *Connection of absolute encoder*

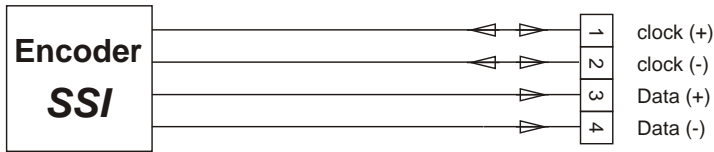

4.5. *Connection of power supply voltage*

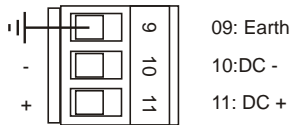

5. *Startup Procedure*



Attention must be paid that the power supply voltage applied will agree with the voltage noticed at the name plate. Switch the power supply on (supply voltage applied to 10 (-) and 11 (+)).

When delivered, the instrument is programmed with a standard configuration (default values). By programming the customer can change the standard configuration according to his measuring task.

When the instrument is built in a machine and the customer wants to change the configuration, attention must be paid, that no damage will occur to the machine!

6. Pushbuttons- and LED-functions

There are four push buttons in the front. These push buttons can have different functions. The functions of the push buttons can be used for programming and for service.

6.1. Function of buttons and LEDs

LED 3	Description
off	encoder- or hold value is displayed
green/flashes	programming mode is activated

LED 1 and LED 2 are not used and have no function

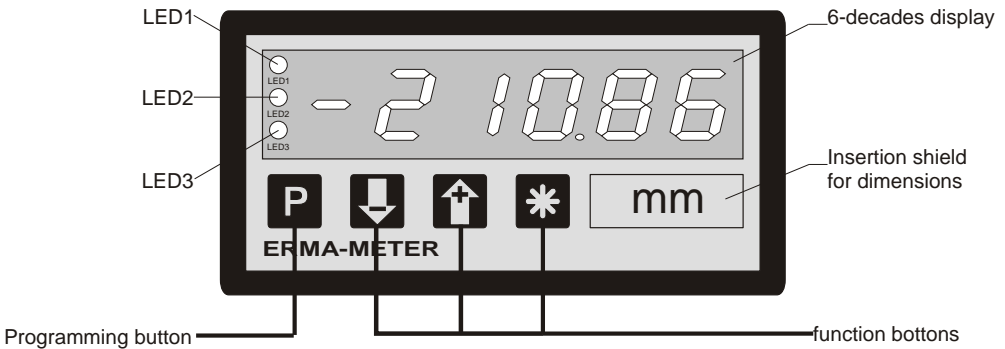

7. Modes

The operation and the programming of the panel meter is organized in several states:



- Operation level
- Access-code level
- Programm level

7.1. Operation level

In the state "operation level" the normal functions of the instrument are activated. A normal measurement cycle looks like below:





- Read the value of encoder, calculate and display

The function of the  -key depends on the value of the parameter **0-08** .

Parameter 0-08 Function of pushbutton 	 by pressing
0	No function
1	displayed encoder value is set to zero
2	clear zero setting

7.2. Access-code level





The state "access-code level" becomes active by pressing the pushbutton  during the state "operation level". The display shows "c000". During the state "access-code level" the normal functions of the instrument are active.

pushbutton	Function
	Confirm of the displayed access-code
	Increase the access-code
	Decrease the access-code
	no function

7.3. Programming level

The state “programm level” becomes active by entering the right access-code. The access-code must be confirm by pressing the pushbutton . The programming is organized in following steps:





- Selection of a programming level
- Selection of a parameter
- Change of the selected parameter

Pushbutton	Press	Pressing during 3 sec.
	Selection of - Programming level - Parameter	-
	Decrease of - Programming level - Number of parameter - Value of parameter	-
	Increase of - Programming level - Number of parameter - Value of parameter	-
	-	Break the programming routine

8. Procedure of programming

The procedure of programming is organized in several different steps.





Access to the selection of the programming levels

- Pressing pushbutton  => access-code enter is active
- The display shows "c000"
- Changing the access-code by pressing the pushbutton  or  and confirm the changed access-code by pressing the pushbutton 



If the entered access-code is not correct, the instrument will jump back to the state "operation level".

8.1. Changing or controlling parameters



Activating the programming routine

- Pressing pushbutton 
- LED 3 flashes green
- The display shows "c000"
- Changing the access-code by pressing the pushbutton  or 
- Confirm access-code by pressing the pushbutton 
- The display shows "P-00"



Leaving the programming routine

- Pressing the pushbutton  or  until the display shows "PEnd"
- Confirm the display "PEnd" by pressing the pushbutton 
- LED 3 is off
- The active state of the panel meter is "operation level"



Selection of the programming level

- Selecting the programming level by pressing the pushbutton  or 
- Confirm the programming level by pressing the pushbutton 
- The display shows the number of the parameter of the selected programming level
For example: "0-00" => parameter 0 of the programming level 0



Leaving the programming level

- Pressing the pushbutton  or  until the display shows “xEnd”
For example: “0End” => leaving programming level 0
For example: “2End” => leaving programming level 2
- Confirm the display “xEnd” by pressing the pushbutton 
- The display shows the programming level
For example: “P-00” => for programming level 0

Selection of the parameter

- Selection the parameter by pressing the pushbutton  or 
- Confirm the parameter by pressing the pushbutton 
- The display shows the last programmed value of the selected parameter

Change and control the selected parameter

- Change the value of the parameter by pressing the pushbutton  or 
- Confirm the value of the parameter by pressing the pushbutton 
- The display shows the programming level and the number of the parameter
For example: “0-05” => parameter 5 of programming level 0

8.2. Overview of the programming levels

The parameters of the panel meter series are organized in different programming levels. According to the design of the panel meter there are several programming levels available.

P-00: Programming level for configuration of the panel meter

The configuration is used to adapt the absolute encoder and the panel meter.

8.3. Programming level for configuration P-00

Param.	Description	Setting range	Default value
0-00	Resolution (Bits)	9 .. 25	12
0-01	Output code 0 -> Gray 1 -> Binary	0 .. 1	0
0-02	Master/Slave-Mode 0 -> Instrument = Master 1 -> Instrument = Slave	0 .. 1	0
0-03	Zero adjustment 0 -> Zero adjustment without sign 1 -> Zero adjustment with \pm display	0 .. 1	0
0-04	Counting direction 0 -> increasing clockwise rotation 1 -> increasing anticlockwise rotation	0 .. 1	0
0-05	Scalingfactor	0.00001 .. 9.99999	1.00000
0-06	Offset value	-99999 .. 999999	0
0-07	Programmable decimal points 0 -> XXXXXX 1 -> XXXXX.X 2 -> XXXX.XX 3 -> XXX.XXX 4 -> XX.XXXX 5 -> X.XXXXX	0 .. 5	0
0-08	Function of pushbutton “-” 0 -> No function 1 -> Display value of encoder 2 -> Display MAX value	0 .. 2	0
0-09	Access-code	0 .. 999	0
0End	Leaving programming level 0		

8.4. Scaling the display range

The scaling of the display range is matched by using a scaling-factor and an offset value. The calculation of the display value looks like below:

$$\text{Display} = (\text{Enc_value} - \text{Zero_adjustmet}) \times \text{Sca_faktor} + \text{Offset value}$$

The overflow or underflow becomes active, if the displayed value is greater than 999999 or smaller than -99999.

- When **overflow** is activ the display shows “nnnnnn”
- When **underflow** is active the display shows “uuuuuu”

8.5. Programming quick reference

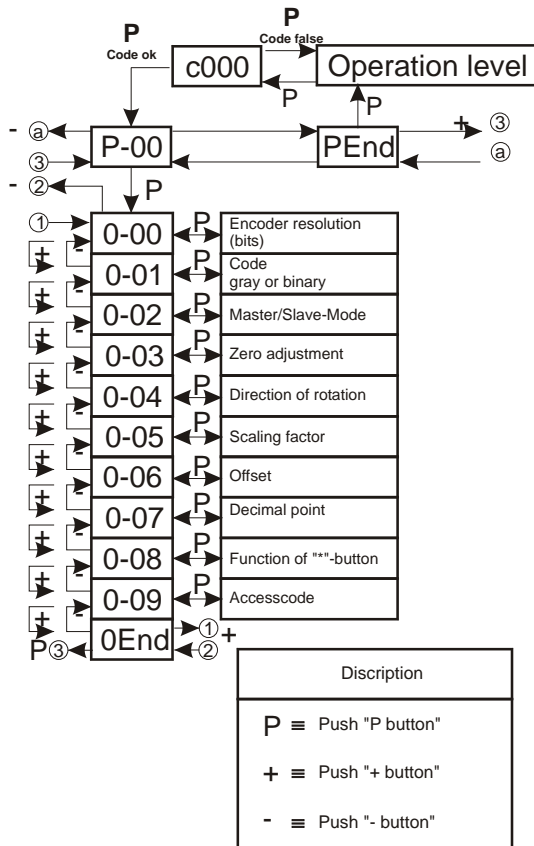

9. Software functions

9.1. Master/Slave-Mode

Master-ModeParameter 0-02 have to be programmed to 0

For reading the value of the encoder the clock is generated by the instrument. A fixed clock frequency of 200 kHz is generated by the instrument.

Slave-Mode:Parameter 0-02 have to be programmed to 1

The clock signal have to be generated by an other instrument. The data transmission between the encoder and the instrument dependent on this "external clock".

In slave mode attention should be paid to:



- External clock may not exceed 100 kHz
- Pause of clock brushes have to be min. 500 µs
- The encoder value can be displayed with 80 values per second

9.2. Zero point adjustment

Sometimes an exactly mechanical zero point adjustment isn't possible. But it's possible to adjust the zero point by software.

9.2.1. Zero point adjustment by pressing button

The zero point can be changed by pressing the  button. Parameter 0-08 have to be programmed to 1.

1. Zero point adjustment with sign: Parameter 0-03 have to be programmed to 1

Example:

Absolute Encoder	SSI-Encoder, singeltur'n
Resolution:	4096 steps per rotation

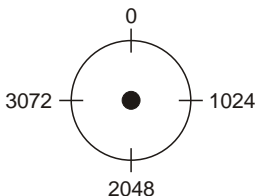

Display range without changing of the zero point

Display range with changing of the zero point

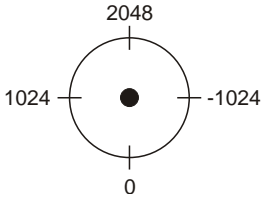

The pushbutton  have been pressed by a display of 2048

2. Zero point adjustment without sign: Parameter 0-03 have to be programmed to 0

Example:

Absolute Encoder SSI-Encoder, singleturn
 Resolution: 4096 steps per rotation

Display range without changing of the zero point

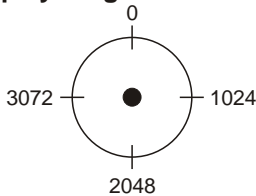

Display range with changing of the zero point

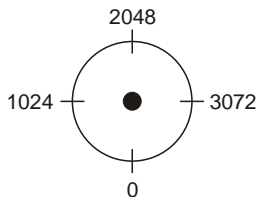

The pushbutton  have been pressed by a display of 2048

9.2.2. Zero point adjustment by offset value

The calculation of the programmed offset value (parameter 0-06) looks like below:

$$\text{Display} = (\text{Enc_value} - \text{Zero_adjustmet}) \times \text{Sca_faktor} + \text{Offset value}$$

There can be a \pm display, as a result of programming an offset value.

Attention should be paid to:

- The charging of the offset value is followed **after** the charging of the scaling-factor.



- The Parameter 0-03 have to be programmed to 1 for a \pm display

9.3. Directions of rotations

The direction of rotation can be changed by software function. The encoder will usually count in increasing direction, if the driving shaft turns with clockwise rotation (top view at the driving shaft).

**Increasing values with clockwise rotation (top view at the driving shaft),
Parameter 0-04 have to be programmed to 0**

**Increasing values with anti-clockwise rotation (top view at the driving shaft),
Parameter 0-04 have to be programmed to 1**

9.4. Main reset

The main reset is performed by pressing a key combination at the front of the panel meter. By doing this all parameters are setting to the default value. The value of the parameter 0-00 (input range) is not changing by the main reset.

During the main reset the display shows "Init."

Perform the main reset by

Pressing the pushbuttons  ,  and  at the same time until "Init" is displayed.

10. Error codes

10.1. Encoder not connected "Err01"

- The display flashes and indicate "Err01"
- Signalizes that no encoder have been connected to the instrument

10.2. Waiting for data input "Err02"

- The display flashes and indicate "Err02"
- Signalizes in slave-mode, that after the connection of an encoder no data input have been received by the instrument.

10.3. External clock frequency too high "Err03"

- The display flashes and indicate "Err03"
- Signalizes in slave mode, that the clock frequency of the "external clock" is too high (> 100 kHz).

11. Technical Specifications

11.1. Electrical datas

SSI signal input	: singleturn or multiturn
Resolution	: 9 .. 25 bit
Code	: binary or gray
Clock output	: driver RS 422/485
Clock input	: receiver RS 422/485
Data input	: receiver RS 422/485
Master mode	
Clock frequency	: internal 200 kHz
Conversion rate	: approximate 80 values/second
Slave mode	
Clock frequency	: external, max. 100 kHz
Break of clock brushes	: min. 500 µs
Conversion rate	: approximate 80 values/second
Power supply DC	: 18 .. 36 V DC (isolated)
power consumption	: max. 50 mA
optional	: 12 V DC, ± 10 % (isolated)
power consumption	: max. 100 mA
optional	: 5 V DC, ± 10 % (isolated)
power consumption	: max. 200 mA
Isolation voltage	: 500 V / 1 min

11.2. Mechanical datas

Display	: 6 decades, 14 mm, red
	: decimal point programmable
	: preliminary zero suppression
	: - sign at negative values
Operation, keyboard design	: front membrane with push buttons
Case	: panel mounting DIN 43 700
Dimensions (B x H x T)	: 96 x 48 x 63,5 mm
Depth	: 72 mm incl. screw terminal
Mounting	: switch board mounting or : mosaic-system mounting
Weight	: approx. 160 g
Connection	: plug-in screw terminal

11.3. Environmental conditions

Operating temperature	: 0 .. 50 °C
Storage temperature	: -20 .. 70 °C
Humidity	: < 80 %, not-condensing
Protection	: protection class II
Front protection	: IP 54
Field of application	: connectors IP 20
CE	: class 2
	: overvoltage protection II
	: in conform with 89/336/EWG
	: NSR 73/23/EWG

12. Ordering Information

SSI 3020 -		0		0	
					Housing
					0 switch board mounting
					1 panel-clip mounting
					reserved
					Front design
					0 reserved
					1 ERMA-Meter Logo
					2 no Logo
					3 customer defined Logo
					reserved
					Power supply
					0 5 V DC, 10 % (isolated)
					1 12 V DC, 10 % (isolated)
					2 18 ... 36 V DC (isolated)

13. Notes

ERMA - Electronic GmbH
Max-Eyth-Str. 8
D-78194 Immendingen

Telefon (+49 7462) 2000-0
Fax (+49 7462) 2000-29
email info@erma-electronic.com
Web www.erma-electronic.com

