TM 2500

Digital Panel Meter

for Thermocouples and Pt100

Instruction Manual



ERMA

Electronic GmbH

Warranty

For delivered products our "Allgemeine Lieferungs- und Zahlungsbedingungen" are effective. In no event ERMA-Electronic or its suppliers shall be liable for any other damages whatsoever (including, without limitation, damages for loss of business profits, business interruption or other pecuniary loss) arising out of or inability to use this product.

All products from ERMA-Electronic are warranted against defective material and workmanship for a period of two (2) years from date of delivery. If it is necessary to return the product to ERMA, the sender is responsible for shipping charges, freight, insurance and proper packaging to prevent breakage in transit. ERMA's warranty does not apply to defects resulting from action of the buyer, such as mishandling, improper interfacing, operation outside of design limits, improper repair or unauthorized modification.

Trademarks

All trademarks they are named or portrayed in the text are registered trademarks of its owner. The trademarks are recognized by ERMA-Electronic.

Contents

1. Description	4
2. Safety instructions	5
2.1. Explanation of symbols	5
3. Mounting	6
3.1. Place of operation	6
3.2. Panel mounting	6
3.2.1. Panel for switch board	6
3.2.2. Panel for mosaic raster	7
4. Electrical connections	8
4.1. General instructions	8
4.2. Hints against noisy environment	8
4.3. Connection and pin assignment	9
4.4. Connection of input signals	9
4.4.1. Thermocouple	9
4.4.2. RTD (Pt100) 2-wire	10
4.4.3. RTD (Pt100) 3-wire	10
4.4.4. Input voltage 0 - 200 mV, 0 - 2 V	10
4.5. Digital inputs	10
4.6. Connection of power supply voltage DC	11
5. Start-Up	11
6. Procedure of programming	12
6.1. Summary of the programming level	13
6.2. Programming level for configuration P-00	14
6.2.1. Cold Junctiont	15
6.2.2. Scaling the display range	16
6.3. Programming level for peak value memory P-02	17
6.4. Programming quick reference	18
7. Software functions	20
7.1. Filtering	20
7.2. Peak value modes	20

7.2.1. Peak value memory	20
7.2.2. Peak value memory single	20
7.2.3. Peak value memory double	21
7.3. Display test	21
8. Technical Specifications	22
8.1. Electric Specifications	22
8.2. Mechanical Specifications	22
8.3. Environmental conditions	23
9. Ordering Information	24
10. Notices	25

Date : 03.02.99
TM2500A.PUB
Technical subjects to change

1. Description

The digital panel meter model **TM 2500** is an universal temperature gauge for connecting the following temperature-sensing head directly:

- Thermocouple type K, J, S, L, and R
- RTD (Pt100) 2-Wire / 3-Wire

In addition the digital panel meter is equipped with signal inputs for

- Voltages 0 - 200 mV DC, and 0 - 2 V DC

Standard hardware components

- Three digital inputs

Standard software functions

- Scaling of voltage inputs
- Rounding last digit
- Filtering
- different peak value memories
- Displaytest

2. Safety instructions

This instrument is produced in accordance with Class II of IEC 348 and VDE 0411. When delivered the instrument has been tested to meet all functions described. Before installing the instrument please read the mounting and servicing instructions. We have no liability or responsibility to customer or any other person or entity with respect to any liability, loss or damage caused or alleged to be caused directly or indirectly by equipment or software sold or furnished by us. Read the installation instruction carefully. No liability will be assumed for any damage caused by improper installation.

Inspect the instrument module carton for obvious damage. Be shure there are no shipping and handing damages on the module before processing. Do not apply power to the instrument if it has been damaged.

ERMA's warranty does not apply to defects resulting from action of the buyer, such as mishandling, improper interfacing, operation outside of design limits, improper repair or unauthorized modifications.

2.1. Explanation of symbols



Caution



Attention



Instruction



Hint

Caution: Will be used at **dangerous for life and health !**

Attention: Will cause **damage**

Instruction: If not noticed, **trouble** may occur

Tip: Useful hints for **better operation**

3. Mounting

3.1. Place of operation

Attention must be paid to the protection against humidity, dust and high temperatures at the place of operation.

3.2. Panel mounting

3.2.1. Panel for switch board

- For mounting in switch boards, insert the case into the panel cutout (according to DIN 43700: $45,0^{+0,6} \times 22,2^{+0,3}$ mm) from the front, using a fresh gasket for sealing as required. Click into and place at each side the two fastening clips (M2,5 x 50 mm).
- Tighten the screws alternately, using enough pressure to get good retention and sealing at the panel.

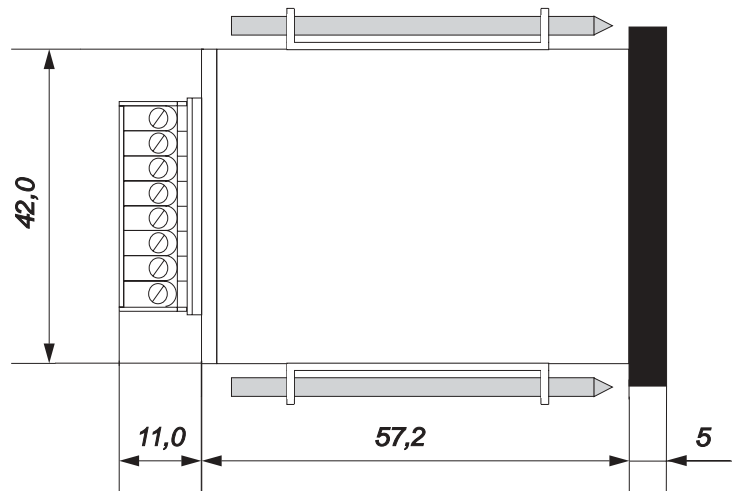
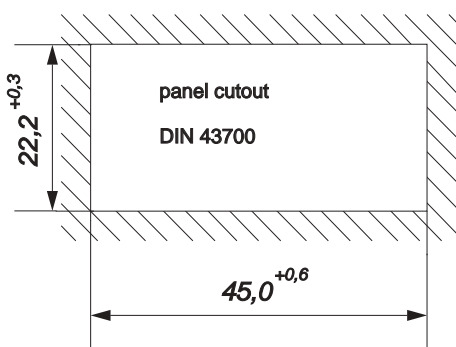
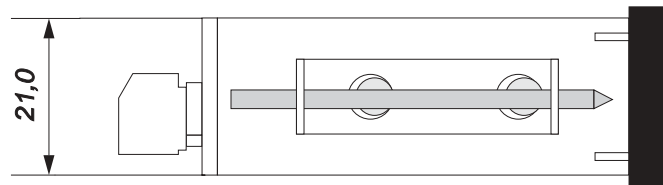
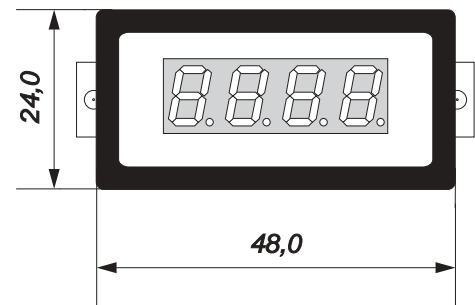

3.2.2. Panel for mosaic raster

- Insert the case into one of the following mosaic-systems:
 - a) Mosaic-system 8RU (M50x25) from Siemens
 - b) Mosaic-system from SubklevGehäuse für Mosaikrastereinbau

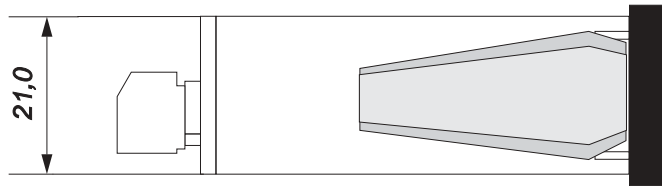
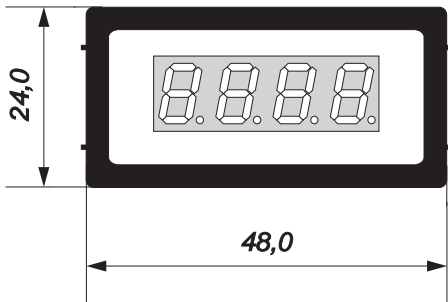

mosaic-system:

Siemens 8RU (M50x25)

Subklev

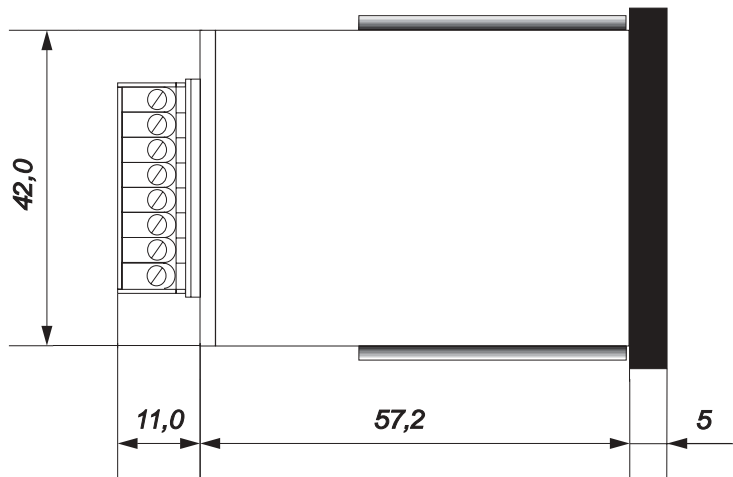

4. **Electrical connections**

4.1. **General instructions**



- It is forbidden to plug or unplug connectors with voltage applied
- Attach input and output wires to the connectors only without voltages applied
- Cords must be provided with sleeves
- Attention must be paid that the power supply voltage applied will agree with voltage noticed at the name plate.
- The instrument has no power-on switch, so it will be in operation as soon as the power is connected.

4.2. **Hints against noisy environment**

All inputs and outputs are protected against noisy environment and high voltage spikes. Nevertheless the location should be selected to ensure that no capacitive or inductive interference can have an effect on the instrument or the connection lines.

It is advisable:



- To use shielded cables.
- The wiring of shields and ground (0V) should be star-shaped.
- The distance to interference sources should be as long as possible. If necessary, protective screen or metal enclosures must be provided.
- Coils of relays must be supplied with filters.
- Parallel wiring of input signals and AC power lines should be avoided.

4.3. Connection and pin assignment

All inputs and outputs are connectors designed as plug-in screw terminals.

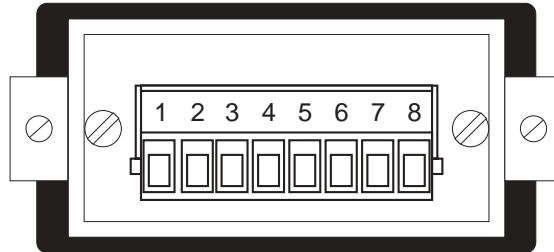

Pin assignment:

01	digital input 1 / displaytest	05	signal input (+) / RTD (Pt100)
02	digital input 2	06	GND / RTD (Pt100)
03	digital input 3 / reset the peak value	07	supply voltage (-)
04	signal input (-) / RTD (Pt100)	08	supply voltage (+)

4.4. Connection of input signals

4.4.1. Thermocouple

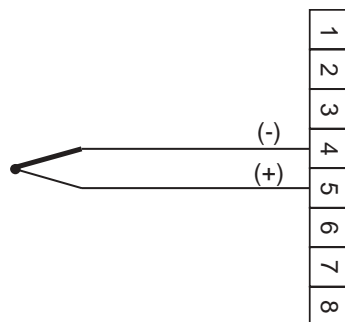

4.4.2. RTD (Pt100) 2-wire

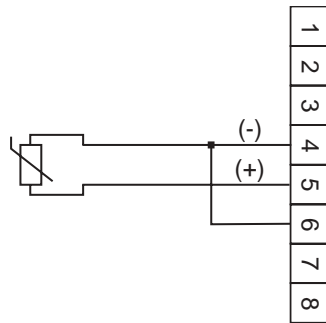

4.4.3. RTD (Pt100) 3-wire

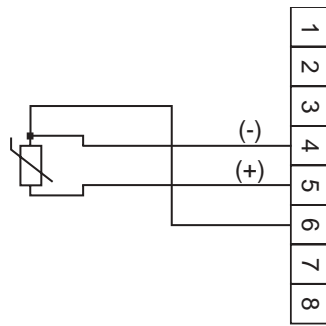

4.4.4. Input voltage 0 - 200 mV, 0 - 2 V

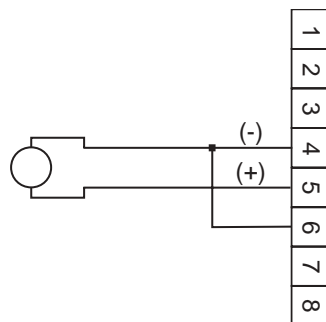

4.5. Digital inputs

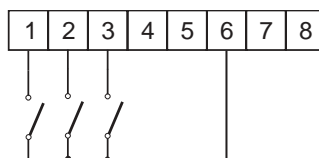

Digital input 1

- display test
- active => connecting screw terminal 1 to 6
- connecting to ground, low active

Digital input 2

- without special function, reserved

Digital input 3

- Reset the peak value memory
- active => connecting screw terminal 3 to 6

connecting to ground, low active

4.6. Connection of power supply voltage DC

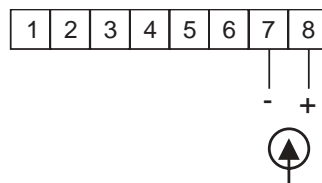

5. Start-Up



Attention must be paid that the power supply voltage applied will agree with the voltage noticed at the name plate.

Switch the power supply on (supply voltage applied to 7 (-) and 8 (+)).



When delivered, the instrument is programmed with a standard configuration (default configuration). According to his measuring task, the customer can change the standard configuration by programming.

Attention: When the instrument is built-in a machine and the customer wants to change the configuration, attention must be paid, that no damage will occur to the machine!

6. Procedure of programming

The procedure of programming is organized in different steps and can be carried out via the screw terminals 1, 2 and 3 at the rear of the instrument. It is advisable to connect a push button to the screw terminals 1 - 3.

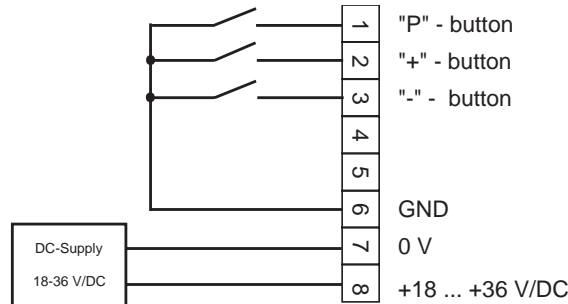

Push Button	Pressing
screw terminal 1 "P"-button	selection of - programming level - parameter
screw terminal 2 "+"-button	increase of - programming level - number of parameter - parameter
screw terminal 3 "-"-button	decrease of - programming level - number of parameter - parameter

Activating the programming routine

- Press "P"-button together with "+"-button
- The display shows "P-00"

Leaving the programming routine

- Press "+"-button or "-"-button until the display shows "PEnd"
- Confirm the display "PEnd" by pressing "P"-button
- Return to normal measuring

Selection of a programming level

- Selecting a programming level by pressing the "+"-button or "-"-button
- Confirm the selected programming level by pressing the "P"-button

- The display shows the parameter number of the selected programming level
e.g.: "0-00" => Parameter 0 of programming level 0
e.g.: "1-00" => Parameter 0 of programming level 1

Leaving a programming level

- Press "+"-button or "-"-button until the display shows "xEnd"
e.g.: "0End" =>leaving programming level 0
e.g.: "1End" =>leaving programming level 1
- Confirm the display "xEnd" by pressing "P"-button
- The display shows the programming level
e.g. "P-00" => programming level 0
e.g. "P-01" => programming level 1

Selection of a parameter

- Selection the parameter by pressing "+"-button or "-"-button
- Confirm the parameter by pressing "P"-button
- The display shows the last programmed value of the selected parameter

Change and confirm a selected parameter

- Change the parameter by pressing the "+"-button or "-"-button
- Confirm the parameter by pressing "P"-button
- The display shows the programming level and the number of the parameter
e.g.: "0-05" => Parameter 5 of programming level 0

6.1. Summary of the programming level

The parameters of the panel meter are organized in different programming levels.

P-00: Programming level for general configuration of the panel meter

The function of the panel meter configuration is used to adapt the sensor and the panel meter.

P-01: Reserved for future applications

P-02: Programming level for maximum value

This programming level is used for the different peak value modes and its parameters.

6.2. Programming level for configuration P-00

Param.	Description	Range	Default Value
0-00	Input range 0 -> Thermocouple type K -100 to +1370 °C 1 -> Thermocouple type J -100 to +1000 °C 2 -> Thermocouple type S 0 to +1750 °C 3 -> Thermocouple type L -100 to +900 °C 4 -> Thermocouple type R 0 to 1590 °C 5 -> RTD (Pt100) 2/3-Wire -200 to +800 °C 6 -> Voltage 0 - 2 V 7 -> Voltage 0 - 200 mV	0 .. 7	0
0-01	Display value of min. input signal for input ranges 6 and 7	-999 .. +9999	0
0-02	Display value of max. input signal for input ranges 6 and 7	-999 .. +9999	+2000
0-03	Programmable points 0 -> XXXX 1 -> XXX.X 2 -> XX.XX 3 -> X.XXX	0 .. 3	0
0-04	Configuration of digit 1 0 -> Display in steps of 1 1 -> Display in steps of 2 2 -> Display in steps of 5 3 -> Display in steps of 10	0 .. 3	0
0-05	Filtering 0 -> no filtering X -> Number of filter cycles	0 .. 99	0
0-06	Resolution 0 -> Resolution 1 °C 1 -> Resolution 0,1 °C only for input ranges 1/3/5	0 .. 1	0
0-07	Cold junction 0 -> Only thermocouple 1 -> Thermocouple + internal cold junction 2 -> Temperature of the internal temperature sensor	0 .. 2	0

6. Procedure of programming

Param.	Description	Range	Default Value
0-08	Correction of cold junction	-20 to +20	0
0-09	Brightness of the display 0 -> Brightness 50 % 1 -> Brightness 100 %	0 .. 1 only valid possible to 9999	1
0End	Leaving programming level P-00	-	-

6.2.1. Cold Junction

The panel meter include an internal temperatur compensation with cold junction reference temperature. By programming **parameter 0-08** (Correction of cold junction) there can be do a correction for the cold junction between -20 to +20°C.

Programmable selection by parameter 0-07:

- Only thermocouple
- Thermocouple + internal cold junction
- Only temperature of the internal temperature sensor

6.2.2. Scaling the display range

The overflow or underflow becomes active if the displayed value is greater or smaller than more as 5-10 % of the programmed display range (parameter 0-01 and 0-02).

- When **overflow** is active the display shows “nnnn”
- When **underflow** is active the display shows “uuuu”

The assignment of the display range to the minimal and maximal input signal is done by programming the parameter 0-01 and 0-02.

Example:

Input range: 0 to +2 V, Display range : -999 to +9999

Step	Param.	Range
1.	0-01	-999
2.	0-02	+9999
3.	0End	End

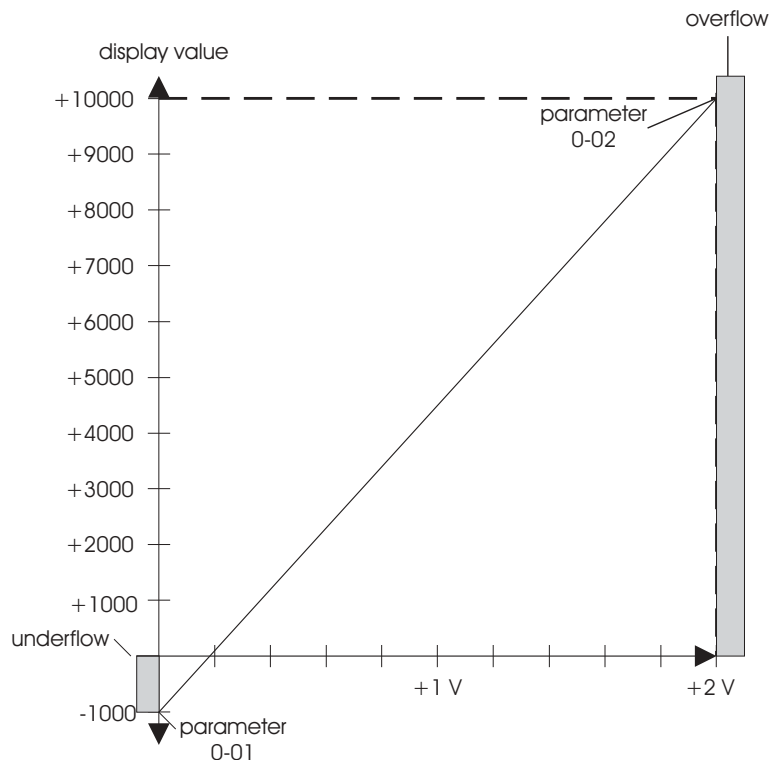

6.3. Programming level for peak value memory P-02

Param.	Description	Range	Default Value
2-00	Peak value mode 0 -> normal working 1 -> peak value memory 2 -> peak value memory single 3 -> peak value memory double	0 .. 3	0
2-01	Signal level for peak value memory single and peak value memory double	-999 .. +9999	100
2-02	Delay time for peak value memory single and peak value memory double	0 .. 99	5
2-03	Memory time for peak value memory single	0 .. 99	5
2-04	Reserve: no function		
2-05	Reserve: no function		
2-06	Reserve: no function		
2-07	Reserve: no function		
2-08	Reserve: no function		
2-09	Reserve: no function		
2End	Leave programming level P-02		

6.4. Programming quick reference

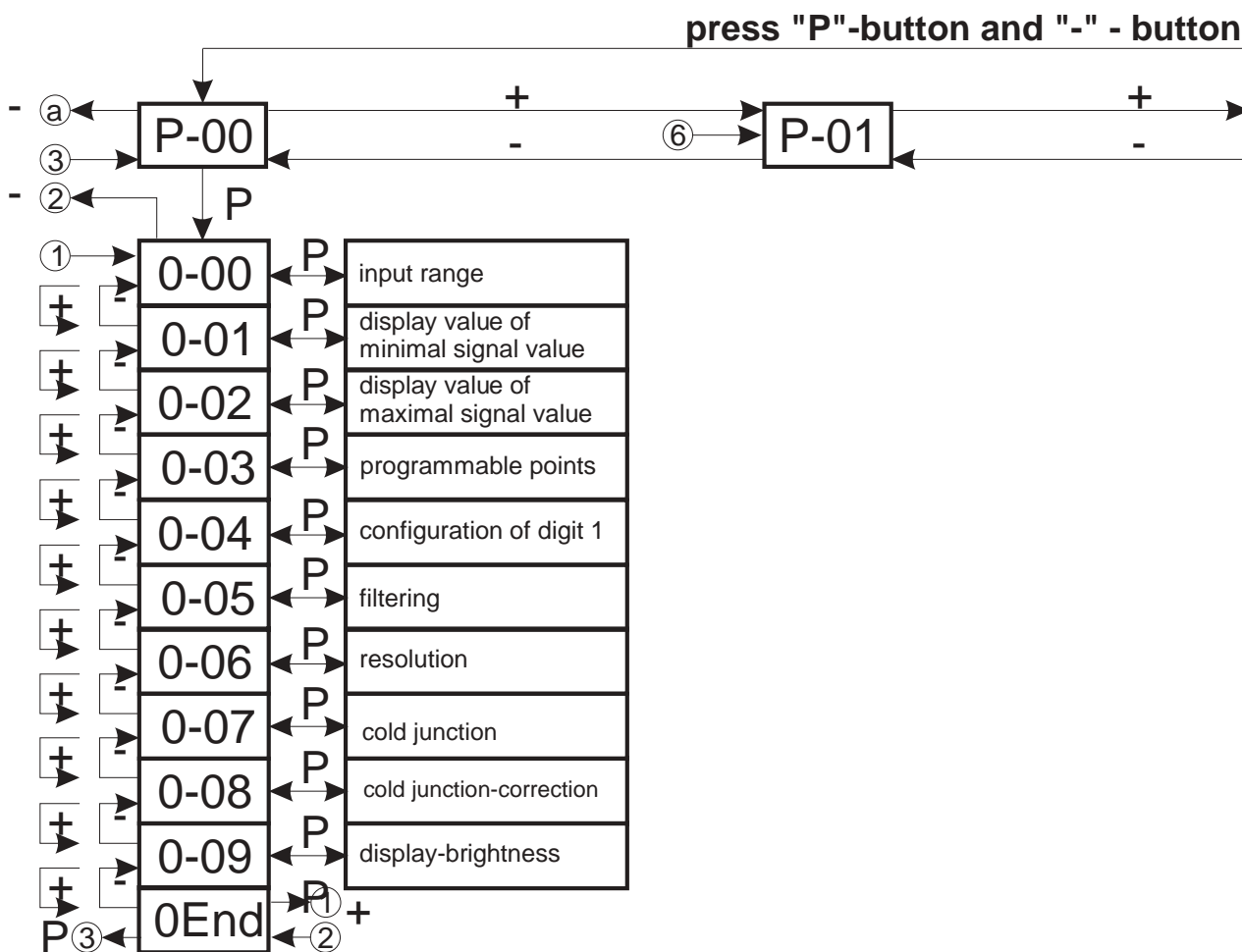

6. Procedure of programming

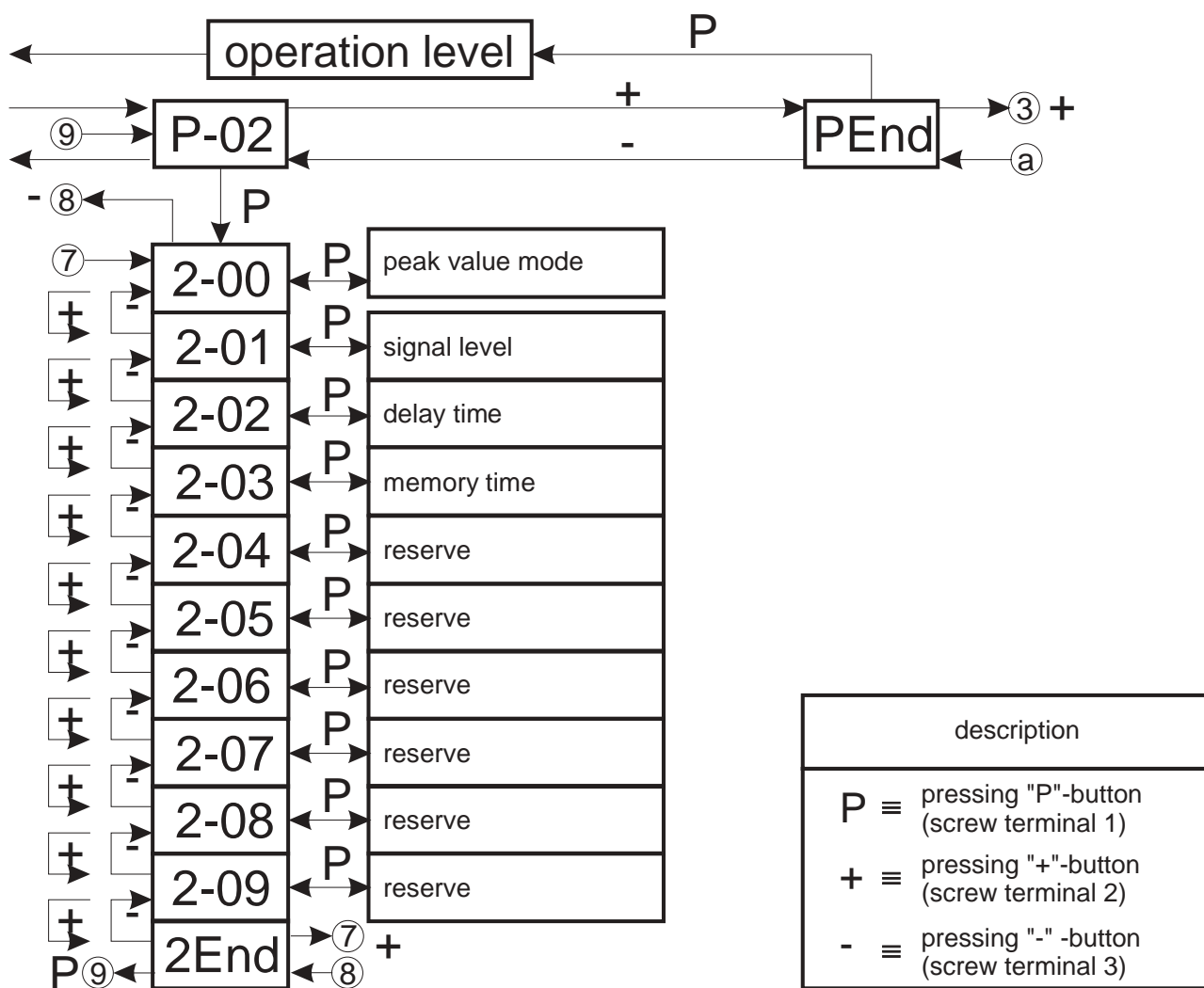

7. Software functions

7.1. Filtering

The panel meter include a programmable single pole digital filter. The filter is used to smooth analog input data in noisy environments.

Digital filtering is performed by forming the average of input signals. By a special algorithm it is provided that a smooth filtering will be achieved.

$$\text{time constant} = \frac{\text{number of measurements}}{\text{conversions rate}}$$

If the input signal is a step function, 99,3 % of the final measurement value will be reached within 5 time constants.

7.2. Peak value modes

The panel meter is equipped with three several peak value modes which can be selected in **parameter 2-00**. In addition there can be programmed a signal level in **parameter 2-01** and a delay time in **parameter 2-02** for the both modes peak value memory single and peak value memory double. For the mode peak value memory single ther can be programmed a memory time in **parameter 2-03**.

7.2.1. Peak value memory

At this mode it will be stored and displayed the highest measured value.

Reset the peak value memory:

- at digital input 3, connect screw terminal 3 to screw terminal 6
- at leaving the programming

7.2.2. Peak value memory single

Is the input signal below the signal level, which is programmed in parameter 2-02, the panel meter works in normaly mode. If the input signal exceeded the programmed signal level and the delay time is run down, the highest input signal will be stored. After the memory time is run down the peak value will be reset.

If a higher signal comes in before the memory time is run down, the memory time starts for a new time. The higher signal will be stored and displayed without the delay time.

The instruments works in normal mode, if the the memory time is run down and the input signal is lower as the signal level. If the input signal is higher as the signal level a new memory time will be started and the signal value will be stored and displayed.

Reset the peak value memory single:

- at digital input 3, connect screw terminal 3 to screw terminal 6
- at leaving the programming

7.2.3. Peak value memory double

If the input signal is below the signal level, which is programmed in parameter 2-02, the panel meter works in normaly mode. If the input signal exceeded the programmed signal level and the delay time is run down the highest input signal will be stored. The memory time is endless.

If a higher signal comes in, the higher signal will be stored and displayed. If the input signal fall under the signal level and exceed the signal level at a new a new start for the peak value takes place.

Reset the peak value memory double:

- at digital input 3, connect screw terminal 3 to screw terminal 6
- at leaving the programming
-

7.3. Display test

When activating the displaytest all segments of the display are light on. The display shows "8.8.8.8."

Activating the display test:

- By activating the digital input 1, connecting screw terminal 1 and 6

8. Technical Specifications

8.1. Electric Specifications

Input ranges

Thermocouples

Ni-CrNi (K)	: - 100 to + 1370 °C
accuracy	: ± 1 °C, ± 1 Digit (> 200 °C)
Fe-CuNi (J)	: - 100 to + 1000 °C
accuracy	: ± 1 °C, ± 1 Digit
PtRh90/10%-Pt (S)	: 0 to + 1750 °C
accuracy	: ± 1 °C, ± 1 Digit (> 250 °C)
Fe-CuNi (L)	: - 100 to + 900 °C
accuracy	: ± 1 °C, ± 1 Digit
PtRh87/13%-Pt (R)	: 0 to + 1590 °C
accuracy	: ± 1 °C, ± 1 Digit (> 200 °C)

cold junction compensation

: internal 0 - 50 °C

accuracy : ± 1 °C

RTD (Pt100)

: 2-wire / 3-wire

: - 200 to + 800 °C

resolution : 0,1 °C or 1 °C

accuracy : ± 1 °C, ± 1 Digit

Voltage

: 0 to 200 mV, ± 0,1 %, ± 1 Digit

: 0 to 2 V, ± 0,01 %, ± 1 Digit

Conversion rate

: 5 measurements/s

Digital inputs

: 10 kΩ pull-up +5 V

Logic : NPN, max. 30 V

Signal level : L-level < 0,4 V

: H-level > 3,5 V

Power supply DC

: 18 .. 36 V DC (isolated)

Power consumption : max. 25 mA (red display)

: max. 40 mA (green display)

optional : 12 V DC, ± 10 % (isolated)

: 5 V DC, ± 10 % (isolated)

8.2. Mechanical Specifications

Display : 4-decades, 8mm

Case : Switch board mounting DIN 43 700

Dimensions : 48 x 24 x 60 mm

Depth : < 70 mm incl. screw terminal

Mounting : Switch board mounting or

: Mosaic-systems

Weight : ca. 150 g
Connection : Plug-in screw terminal

8.3. Environmental conditions

Operating temperature : 0 .. 50 °C
Storage temperature : - 20 .. 70 °C
Humidity : < 80 %, not-condensing
Front protection : class II
: connection IP 20
CE : in conform with 89/336/EWG

9. Ordering Information

TM 2500 -					
					Case
					0 Panel mounting
					1 Panel-clip
					Front becel color
					0 Black
					1 Grey RAL 7037
					2 Grey RAL 7032
					3 Grey RAL 7035
					Front design
					0 only filter plate
					1 Front ALU
					2 Front RAL 7032
					3 Front RAL 7035
					Display color
					0 red
					1 green
					Power supply
					0 5 V DC, ± 10 % (isolated)
					1 12 V DC, ± 10 % (isolated)
					2 18 bis 36 V DC (isolated)

10. Notices

ERMA - Electronic GmbH
Max-Eyth-Straße 8
78194 Immendingen

Telefon (0049) 7462/7381
Fax (0049) 7462/7554
email erma-electronic@t-online.de

